

# On OFDM Subcarrier Allocation Strategies for Soft Hand-off in Cellular Systems

**Chanhong Kim and Jungwoo Lee**

Department of Electrical and Computer Engineering  
Seoul, 151-744, Korea

[e-mail: [chkim@wspl.snu.ac.kr](mailto:chkim@wspl.snu.ac.kr) and [junglee@snu.ac.kr](mailto:junglee@snu.ac.kr)]

\*Corresponding author: Jungwoo Lee

*Received November 28, 2011; revised February 28, 2012; accepted March 13, 2012;  
published March 25, 2012*

---

## **Abstract**

This paper deals with subcarrier allocation strategies for soft hand-over in OFDMA-based cellular systems. Two possible subcarrier allocation methods are considered for soft hand-over. One method is to use an identical subcarrier set between the two cells participating in the hand-over. The other is to use different subcarrier sets between the two cells. As expected, the different subcarrier strategy is better in terms of diversity order and BER than the identical subcarrier strategy. It will be shown that the BER performance difference between the two strategies is more noticeable with contiguous subcarrier allocation. But the different subcarrier strategy consumes twice more frequency resources than the other, and there is a trade-off between the two strategies in terms of BER and frequency resources. By considering the trade-off, we also propose a subcarrier allocation strategy for soft hand-over.

---

**Keywords:** Soft hand-over, OFDM, subcarrier allocation

---

This research was supported in part by NRF programs (2010-0013397, 2010-0027155), Seoul R&BD Program (JP091007, 0423-20090051), the KETEP grant (2011T100100151), INMAC, and BK21. This paper was presented in part at the IEEE 61st Vehicular Technology Conference (VTC), Stockholm, Sweden, 30 May – 1 June, 2005.

**DOI: 10.3837/tiis.2012.03.001**

## 1. Introduction

**E**merging beyond-3G cellular standards such as 3GPP LTE-Advanced and IEEE 802.16m will be based on OFDM technologies. Due to the cellular nature of these standards, hand-over (or hand-off) is required for mobile users. There are two types of hand-over: hard hand-over and soft hand-over (SHO). Since SHO is capable of seamless communications even if base station is changed, it is an important research issue in cellular networks. However, unlike CDMA SHO, there does not exist much literature on SHO in OFDM [1][2][3][4][5].

We focus on the SHO in this paper because it requires more careful analysis in terms of diversity combining. Only the downlink (forward link) is considered in this paper. In [1][2][3][4], the medium access control (MAC) or higher layer aspects of SHO are discussed, but the physical layer (PHY) aspect of SHO was not discussed. It was not clear whether identical subcarriers can be used or not between two cells in SHO, which is one of the main topics discussed in this paper. In [5], although the PHY aspect of SHO was discussed, it focused on the cooperative MIMO base stations.

The cyclic prefix in OFDM is used to maintain the orthogonality of OFDM subcarriers in multipath channels. It also has some diversity combining capability as long as the delay spread of the channel lies within the cyclic prefix. The multipath diversity in OFDM is discussed in [6],[7]. One important system factor that affects the soft hand-over performance is the subcarrier allocation strategy. Another important factor in designing an allocation strategy is whether the subcarriers used for one user is contiguous or not. The contiguous case is conventionally *block* allocation, and the non-contiguous case is called *interleaved* allocation. Other factors that we consider include the delay spread of the channel and the mobile's location in an anchor cell. The location determines the mean arrival time difference between the two base station signals. We will analyze how all these factors affect the performances of different subcarrier allocation strategy. In this work, we will assume that the cells (base stations) are synchronized by GPS.

## 2. Signal Model

At the transmitter, the time-domain OFDM signal can be represented by

$$x_c(t) = \frac{1}{\sqrt{N}} \sum_{k=0}^{N-1} X(k) e^{-j2\pi f_k t}, \quad (1)$$

where  $N$  is the size of FFT points and  $X(k)$  is the data symbol at  $k$  th subcarrier. Note that  $f_k = \frac{k}{T} = \frac{k}{NT_s}$  where  $T$  and  $T_s$  are the OFDM symbol period and the sampling period, respectively. The sampled signal is denoted by  $x(n) = x_c(nT_s)$ .

In practical implementation, the received signal would be a sampled version of  $y_c(t) = g(t) * x_c(t) + w(t)$  where  $g(t)$  is the channel impulse response, and  $w(t)$  is the white Gaussian noise. The sampled received signal and the sampled noise are denoted by  $y(n) = y_c(nT_s)$  and  $w(n) = w_c(nT_s)$ , respectively. The discrete time version of  $g(t)$  is

denoted by  $g(n)$  although it is not exactly the same as  $g(nT_s)$ . The DFT's of  $x(n)$  and  $g(n)$  are denoted by  $X(k)$  and  $H(k)$ . Let us denote the vectorized version of the above signals by  $\mathbf{g} = [g(0), g(1), \dots, g(N-1)]^T$ ,  $\mathbf{x} = [x(0), x(1), \dots, x(N-1)]^T$ ,  $\mathbf{X} = [X(0), X(1), \dots, X(N-1)]^T$ ,  $\mathbf{H} = [H(0), H(1), \dots, H(N-1)]^T$ , and  $\mathbf{w} = [w(0), w(1), \dots, w(N-1)]^T$ . The DFT matrix is given by  $[W_{lm}]$  where  $W_{lm} = \frac{1}{\sqrt{N}} e^{-j\frac{2\pi}{N}lm}$ . Note that the IDFT matrix is  $\mathbf{F}^{-1} = \mathbf{F}^H$  since  $\mathbf{F}$  is unitary. We also have  $\mathbf{H} = \mathbf{F}\mathbf{g}$ . The frequency-domain received signal vector after DFT is then given by  $\mathbf{Y} = \mathbf{F}(\mathbf{g} \otimes (\mathbf{F}^H \mathbf{X}) + \mathbf{w})$  where  $\otimes$  is circular convolution, and  $\mathbf{w}$  is the white noise with covariance of  $E[\mathbf{w}\mathbf{w}^H] = \sigma_n^2 \mathbf{I}_N$ . We then have  $N$  independent parallel channels.

$$Y(k) = H(k)X(k) + \tilde{w}(k), \quad (2)$$

where  $\mathbf{Y} = \mathbf{F}\mathbf{y}$ , and  $\tilde{\mathbf{w}} = \mathbf{F}\mathbf{w}$ . Note that the covariance matrix of  $\tilde{\mathbf{w}}$  is also  $E[\tilde{\mathbf{w}}\tilde{\mathbf{w}}^H] = \sigma_n^2 \mathbf{I}_N$  because  $\mathbf{F}$  is unitary.

### 3. Multipath Diversity and Combining Strategy

We consider two subcarrier allocation strategies for SHO. One is to use an identical set of subcarriers, and the other is to use different sets of subcarriers. In OFDMA-based cellular systems, a resource block is usually composed of several subcarriers, which is the smallest unit for resource allocation. For example, in an OFDM system with 16 subcarriers, if a resource block has 4 subcarriers, there are 4 resource blocks per an OFDM symbol. With the identical set of subcarriers for SHO, both of the two base stations allocate the same resource block number to a HO user. On the other hand, with the different sets of subcarriers, each base station allocates a different resource block number to a HO user. In the first strategy, we take advantage of the multipath diversity capability of cyclic prefix, which is used at the beginning of every OFDM symbol. In the second approach, one of the key benefits is the increased frequency diversity. It should be noted that the used frequency resources of the 2nd approach is twice as much as those of the 1st approach. There are two types of gain available with diversity techniques. One is the combining (or MRC) gain, which is due to the added SNR's of diversity branches. The other is the diversity gain (order), which is due to the fact that it is unlikely that all the branches are in deep fade simultaneously. For the different subcarrier strategy, maximal ratio combining (MRC) can be used, and it is well known that the combiner output SNR is the sum of individual branch SNR's [8]. It can be easily shown that the diversity order for the MRC of uncorrelated branches is the number of branches, which is 2 in this case [7].

Let us consider the combining (SNR) gain and the diversity order for the SHO scenario using the identical subcarrier. Note that the MRC cannot be used in this scheme because the channel coefficient cannot be estimated for each branch. As shown in Fig. 1,  $H_1(k)$  and  $H_2(k)$  are the frequency-domain channel response from base station (BS) 1 and 2, respectively. The received time-domain signal is

$$y(n) = (g_1 * x)(n) + (g_2 * x)(n - n_d) + w(n), \quad (3)$$

where  $n_d$  is the arrival time difference between the two signals from BS 1 and BS 2,  $g_1$  and  $g_2$  are the IDFT's of  $H_1(k)$  and  $H_2(k)$ , respectively. Since the time-shift in time-domain corresponds to the complex exponential multiplication in frequency-domain, we have

$$Y(k) = \left( H_1(k) + e^{-j\frac{2\pi}{N}kn_d} H_2(k) \right) X(k) + \tilde{w}(k). \quad (4)$$

Note that  $\mathbf{H}_1 = \mathbf{F}\mathbf{g}_1$  and  $\mathbf{H}_2 = \mathbf{F}\mathbf{g}_2$ . It is assumed that  $g_1$  and  $g_2$  are uncorrelated.

The complex coefficient of  $X(k)$  in (4) determines the SNR gain. This can be verified by looking at the power of the coefficient

$$\begin{aligned} & E \left[ \left| H_1(k) + e^{-j\frac{2\pi}{N}kn_d} H_2(k) \right|^2 \right] \\ &= E \left[ |H_1(k)|^2 \right] + E \left[ |H_2(k)|^2 \right] + 2\Re \left[ e^{j\frac{2\pi}{N}kn_d} E \left[ H_1(k) H_2^*(k) \right] \right] \end{aligned} \quad (5)$$

Let us consider the covariance matrix of  $\mathbf{H}$ , which is given by  $E[\mathbf{H}\mathbf{H}^H] = E[\mathbf{F}\mathbf{g}_1\mathbf{g}_2^H\mathbf{F}^H] = \mathbf{F}E[\mathbf{g}_1\mathbf{g}_2^H]\mathbf{F}^H$ . Since  $g_1$  and  $g_2$  are uncorrelated,  $E[\mathbf{g}_1\mathbf{g}_2^H] = 0$  so  $E[\mathbf{H}\mathbf{H}^H] = 0$ . Hence (5) becomes  $E[|H_1(k)|^2] + E[|H_2(k)|^2]$ . The mean output SNR of the identical subcarrier strategy is thus the same as that of the different subcarrier strategy. However, the two strategies are different in terms of diversity order. It is obvious that the different subcarrier SHO scheme has the diversity order of 2. On the other hand, it can be shown that the 2-branch multipath in OFDM has the diversity order of 1 instead of 2 [7], which indicates that the different-set strategy performs better than the identical-set strategy.

The above analysis indicates that OFDM with cyclic prefix provides some multipath diversity gain. The OFDM diversity issue can be casted in the framework of diversity/multiplexing tradeoff [9]. Without cyclic prefix, a full rate transmission is possible for the channel without ISI, but diversity gain cannot be achieved because any delay spread of the channel introduces interference. By using cyclic prefix, the rate is sacrificed a little bit, but we do get some diversity gain. This indicates that there is a tradeoff between transmission rate and diversity gain. This tradeoff for general ISI channels is analyzed in [10]. Since the maximum likelihood (ML) sequence estimation is the optimal decoder for an ISI channel, the paper derives the tradeoff in terms of error. It was shown that the ML decoder satisfies  $P_e \approx \text{SNR}^{-d(r)}$  where  $d(r) = L(1 - r')$  and  $r' = (1 - \frac{L-1}{N})r$ . Note that  $r$  is the normalized transmission rate (1 is the maximum),  $d(r)$  is the diversity order which is a function of  $r$ ,  $L$  is the number of channel delay taps, and  $N$  is the length of code block. When  $N \rightarrow \infty$ ,  $r' \rightarrow r$ . The tradeoff between  $r$  and  $d$  is shown in Fig. 2, which is the upper bound for the operating point of an OFDM system with cyclic prefix. Since the same information is transmitted in SHO, the effective data rate is  $r = \frac{1}{2}$ . We also have  $L = 2$ . Based on the above tradeoff, the diversity order is  $d(r) = L(1 - r) = 1$ , which is consistent with the analysis in [7].

In practice, the effective data rate is even lower than  $\frac{1}{2}$  because the usage of cyclic prefix reduces the rate further. The new rate including the cyclic prefix effect is  $r = \frac{1}{2} \frac{N-N_{CP}}{N} < \frac{1}{2}$ . Note that the operating rate of OFDM with cyclic prefix is  $r = \frac{N-N_{CP}}{N}$  where  $N_{CP}$  is the size of the cyclic prefix, which indicates the reduction of rate due to the cyclic prefix. The above relationship also indicates that we can increase the diversity order by sacrificing the rate of cyclic prefix.

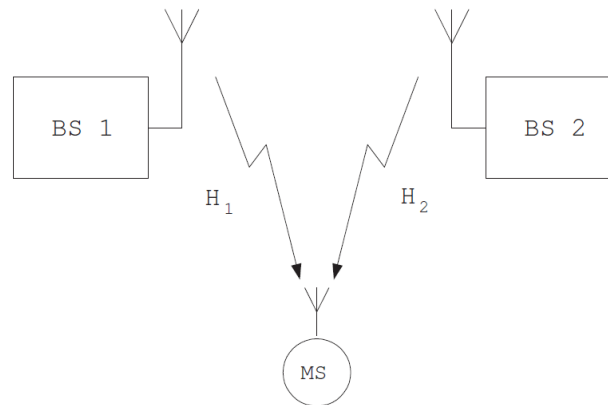

**Fig. 1.** Downlink soft hand-over from two base stations (BS 1 and 2).  $H_1$  and  $H_2$  are the channel responses for the two base stations.

### SHO resource allocation policy

As will be observed in simulations, it is desirable to use the different-set subcarrier allocation strategy for the contiguous case even if it consumes twice the channel resources. In the non-contiguous case, there is a tradeoff between BER performance and resource savings. One way to decide is to change the resource allocation policy depending on the loading factor of the cells. In other words, the different-set strategy can be used when the loading factor is low (when a pool of unused resources is available), and the identical-set strategy is used otherwise.

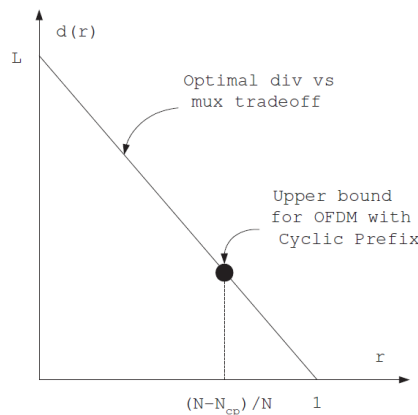

**Fig. 2.** Optimal diversity and multiplexing (rate) tradeoff curve for general ISI channels.  $L$  is the delay spread (in number of taps)

## 4. Simulations

For simulations, we developed a software which models basic features of the WiMAX standard (IEEE 802.16e) [11]. More specifically, we used 1024-FFT, 864 subcarriers (16 subchannels x 54 subcarrier/subchannel), 128 cyclic prefix samples, and the bandwidth of 10 MHz. The sampling period is 100 ns. Only 864 tones out of 1024 are used for data, and the others are used for null subcarriers (guard band). The modulation is QPSK for each subcarrier. In SHO, the Tx powers of two base stations are equal. For fair comparison, the power of each base station in SHO is set to one half of the Tx power in the single cell case. A convolutional code with rate of 1/2 is used. The channel model is based on the exponential delay profile with varying RMS delay spread. We also use a path-loss model with path-loss exponent of 4.41, and log-normal shadowing with standard deviation of 6.15 dB. The cell radius is  $r = 3$  km. The channel estimation was assumed to be ideal in the simulations, and MRC is used for combining two signals for the different-subcarrier SHO strategy.

The two soft hand-over strategies in terms of subcarrier allocation are considered. In the following figures,  $N_{BS} = 1$  means the single cell case (not in SHO mode), and  $N_{BS} = 2$  stands for two-cell case (in SHO mode). The identical-set case is denoted by “same”, and the different-set case is denoted by “diff”. The contiguous and the non-contiguous subcarriers are denoted by “cont” and “noncont”, respectively.

Simulations show that the performances of the two SHO strategies depend on whether the subcarriers are contiguous or not. Fig. 3 and Fig. 4 show the BER comparison for two different positions (arrival time difference) of a mobile station. The two mobile positions that we considered are  $r$  ( $t_d = 0\mu s$ ) and  $0.7r$  ( $t_d = 6\mu s$ ). The distance is measured from the center (base station) of a cell. The parameters common to the two figures are the maximum delay spread of the exponential delay profile ( $\tau_{max} = 5\mu s$ ), the RMS delay spread ( $\tau_{rms} = 1\mu s$ ), and the Doppler frequency ( $f_D = 250$ Hz).

Fig. 5 and Fig. 6 show the BER comparison for the two different RMS delay spreads. One case is for  $\tau_{rms} = 1\mu s$  with  $\tau_{max} = 5\mu s$ , and the other case is for  $\tau_{rms} = 4\mu s$  with  $\tau_{max} = 20\mu s$ . The common parameters for these two figures are  $f_D = 250$  Hz and  $t_d = 2\mu s$  corresponding to the position of  $0.9r$ . It is observed that the case with larger delay spread has better BER performance than the case with smaller delay spread. This is due to the multipath (frequency) diversity.

In all the 4 figures, it is observed that the different-set strategy is always better than the identical-set strategy regardless of the contiguity of subcarriers. This is consistent with the theoretical prediction that the diversity order of the different-set scheme is larger than that of the identical-set scheme. Note that the delay spread in the channel also provides additional diversity on top of the SHO diversity, which makes the BER slope steeper as can be seen in Fig. 6. Depending on the channel parameters, the different-set scheme is 3-4 dB better than the identical-set scheme for the non-contiguous case at  $10^{-3}$  BER. The different-set scheme is 6-7.5 dB better than the identical-set scheme for the contiguous case at  $10^{-3}$  BER. As for the single cell case, the non-contiguous scheme is 3-10 dB better than the contiguous scheme at  $10^{-3}$  BER. The results indicate that the improvement of the different-set scheme over the identical-set scheme is more prominent with the contiguous subcarriers. As for the non-contiguous subcarriers, frequency diversity is already present so that the additional diversity gain with the different subcarrier scheme will be less noticeable.

We also compared the hand-over strategies with the single cell case where the transmit power is the same as the sum of the powers of the two base stations in soft hand-over case. Since SHO can be viewed as the communication over a two-path channel with a large delay spread, the SHO case performs better than the single cell case due to the increased frequency diversity. As long as the delay spread lies within the cyclic prefix, it is expected that the BER performance of the soft hand-over is better than that of single cell case, which was also observed in all the 4 figures. This is an empirical evidence that multipath diversity exists with OFDM with cyclic prefix.

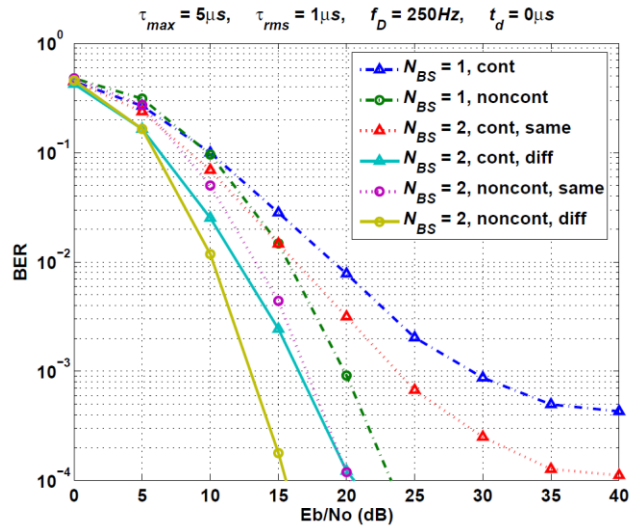

**Fig. 3.** BER comparison of different soft hand-over strategies when a mobile is located at  $r$  (3km) which corresponds to  $0 \mu s$ .

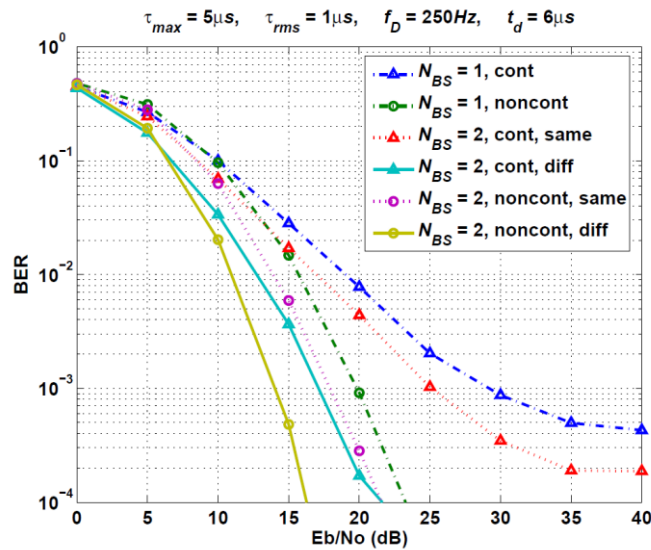

**Fig. 4.** BER comparison of different soft hand-over strategies when a mobile is located in the middle ( $0.7r$  (2.1km) which corresponds to  $6 \mu s$ ).



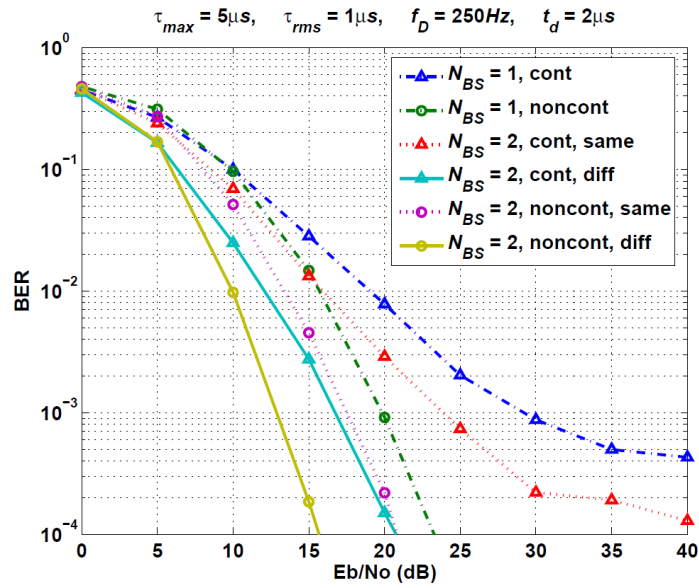

Fig. 5. BER comparison of different soft hand-over strategies when the RMS delay spread is  $1\mu s$ .

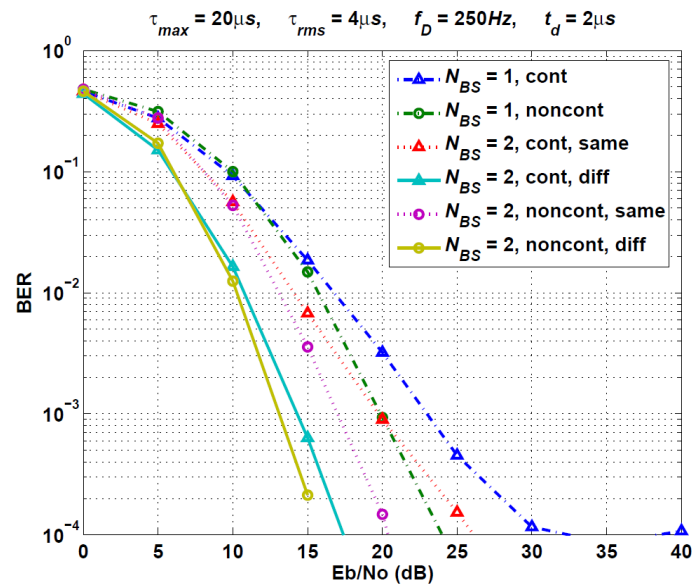

Fig. 6. BER comparison of different soft hand-over strategies when the RMS delay spread is  $4\mu s$ .

### 5. Conclusion

We showed that the cyclic prefix in OFDM has the capability of multipath diversity. We compared two soft hand-over strategies in terms of subcarrier allocation. It was found that using the different-subcarrier strategy produces the best BER performance regardless of contiguity of subcarriers, which is expected. For the contiguous case, the different-subcarrier



strategy performs even better than the identical subcarrier strategy. But the different-subcarrier strategy requires twice more frequency resources than the identical subcarrier strategy although the former has better BER performance than the latter. Hence there is a trade-off between the two strategies. Based on the observation, a SHO subcarrier allocation technique which depends on the loading factor of a cell is proposed.

## References

- [1] G. Lupo, R. Cautellier, M. G. Di Benedetto and F. Malena, "Dynamic resource allocation with a soft handover procedure for application in a broadband system," in *Proc. of 50th IEEE Vehicular Technology Conference*, vol.4, pp.2111-2115, Sept.1999. [Article \(CrossRef Link\)](#)
- [2] Jaeho Jo and Jinsung Cho, "Cross-layer optimized vertical handover schemes between mobile WiMAX and 3G networks," *KSII Transactions on Internet and Information Systems*, vol.2, no.4, pp.171-183, Aug.ust 2008. [Article \(CrossRef Link\)](#)
- [3] Byungjoo Park, Eunsang Hwang and Gil-Cheol Park, "Seamless mobility management in IP-based wireless/mobile networks with fast handover," *KSII Transactions on Internet and Information Systems*, vol.3, no.3, pp.266-284, Jun.2009. [Article \(CrossRef Link\)](#)
- [4] Hung Quoc Vo, Daesun Kim, Choong Seon Hong, Sungwon Lee and Eui-Nam Huh, "A novel scheme for seamless hand-off in WMNs," *KSII Transactions on Internet and Information Systems*, vol.3, no.4, pp.399-422, Aug.2009. [Article \(CrossRef Link\)](#)
- [5] Antti Tölli, Marian Codreanu and Markku Juntti, "Cooperative MIMO-OFDM cellular system with soft handover between distributed base station antennas," *IEEE Transactions on Wireless Communications*, vol.7, no.4, pp.1428-1440, Apr.2008. [Article \(CrossRef Link\)](#)
- [6] C. Tepedelenlioglu, "Maximum multipath diversity with linear equalization in precoded OFDM systems," *IEEE Transactions on Information Theory*, vol.50, no.1, pp.232-235, 2004. [Article \(CrossRef Link\)](#)
- [7] A. Damman, P. Lusina and M. Bossert, "On the equivalence of space-time block coding with multipath propagation and/or cyclic delay diversity in OFDM," in *Proc. of IEEE European Wireless*, 2002.
- [8] J. G. Proakis, *Digital communications, 4th Edition, McGraw-Hill*, 2001.
- [9] L. Zheng and D. N. C. Tse, "Diversity and multiplexing: a fundamental tradeoff in multiple-antenna channels," *IEEE Transactions on Information Theory*, vol.49, pp.1073-1096, May.2003. [Article \(CrossRef Link\)](#)
- [10] L. Gropop and D. N. C. Tse, "Diversity/multiplexing tradeoff in ISI channels," in *Proc. of IEEE International Symposium on Information Theory*, pp.96, Jun.2004. [Article \(CrossRef Link\)](#)
- [11] IEEE P802.16e/D4, "Draft IEEE standard for local and metropolitan area networks - Part 16: air interface for fixed and mobile broadband wireless access systems," Aug. 2004.



**Chanhong Kim** received the B.S. degree and the Ph. D. degree in electrical engineering from Seoul National University, Seoul, Korea in 2004 and 2011. He currently works as a technical staff at Samsung Electronics, Suwon, Korea. His research interests include link adaptation, modulation, and coding for wireless communications, with current emphasis on analysis of multiuser MIMO techniques.



**Jungwoo Lee** received the B.S. degree in Electronics Engineering from Seoul National University, Seoul, Korea in 1988, and the M.S.E. degree and the Ph.D. degree in Electrical Engineering from Princeton University in 1990 and 1994. He was a member of technical staff working on multimedia signal processing at Sarnoff Corporation from 1994 to 1999. He has been with Wireless Advanced Technology Lab of Lucent Technologies since 1999, and worked on W-CDMA base station algorithm development. He is currently a professor at Department of Electrical and Computer Engineering, Seoul National University. His research interests include wireless communications, signal processing, communications ASIC architecture/design, multiple antenna systems, and wireless video. He holds 12 U.S. patents. He is an associate editor for IEEE Transactions on Vehicular Technology.