

A Linear Precoding Technique for OFDM Systems with Cyclic Delay Diversity

Bing Hui and KyungHi Chang

The Graduate School of Information Technology & Telecommunications, Inha University
253 Yonghyun-Dong, Nam-Gu, Incheon 402-751, Incheon, Korea
[e-mail: huibing_zxo@163.com, khchang@inha.ac.kr]
*Corresponding author: KyungHi Chang

*Received August 20, 2008; revised September 26, 2008; accepted September 30, 2008;
published October 25, 2008*

Abstract

Cyclic delay diversity (CDD) is considered a simple approach to exploit the frequency diversity, to improve the system performance in orthogonal frequency division multiplexing (OFDM) systems. Also, the linear precoding technique can significantly improve the performance of communication systems by exploiting the channel state information (CSI). In order to achieve enhanced performance, we propose applying linear precoding to the conventional CDD-OFDM transmit diversity schemes over Rayleigh fading channels. The proposed scheme works effectively with the accurate CSI in time-division-duplex (TDD) OFDM systems with CDD, where the reciprocity is assumed instead of channel state feedback. For a BER of 10^{-4} and the mobility of 3 km/h, simulation results show that a gain of 6 dB is achieved by the proposed scheme over both flat fading and Pedestrian A (Ped A) channels, compared to the conventional CDD-OFDM system. On the other hand, for a mobility of 120 km/h, a gain of 2.7 dB and 3.8 dB is achieved in flat fading and Vehicular A (Veh A) channels, respectively.

Keywords: Cyclic delay diversity, linear precoding, OFDM, reciprocity, frequency-division-duplex (FDD), TDD

1. Introduction

OFDM is a spectral efficient modulation scheme that transforms a frequency selective channel into a set of frequency flat channels, and therefore permits simple equalization schemes. However, OFDM-based transmission systems suffer from the lack of built-in diversity. In order to achieve high reliability and availability without using additional spectral resources, diversity schemes, such as spatial diversity, can be employed with OFDM systems.

Delay diversity (DD) has been proposed as a simple transmit diversity method for systems with multiple transmit antennas, where delayed versions of the same signal are transmitted from different antennas. At the receiver side, the diversity can then be exploited without any additional computational burden. In other words, this scheme only requires a simple conventional single-input single-output (SISO) OFDM receiver. In OFDM systems with DD, the increased frequency selectivity caused by the introduced delays can be picked up by the forward error correction (FEC) decoder. However, the possible respective maximum delays are strongly restricted by the length of the cyclic prefix (CP). A neat way to overcome this problem is to use cyclic delay diversity as proposed in [1]. Another advantage of CDD over other transmit diversity techniques, such as space-time block codes (STBC) [2], is that there is no rate loss even for a large number of transmit antennas.

The performance of the communication system can be improved when the transmitter knows the channel state. The linear precoder, which is constructed by considering the feedback CSI from the receiver side, is quite simple and widely used. Therefore, we propose applying linear precoding to the conventional CDD-OFDM systems, to improve the system performance, such as link reliability, etc. The simulation results show that the proposed scheme can achieve a dramatic gain improvement. The low complexity is another advantage of the proposed scheme.

The remainder of this paper is organized as follows. First, we introduce and analyze the CDD scheme in detail in Section 2, and in Section 3 a multiple-input multiple-output (MIMO) linear precoding technique is presented. Section 4 presents the proposed scheme for combining CDD with precoding in detail. In Section 5, the simulation results are discussed. Finally, conclusions are provided in Section 6.

2. Principle of Cyclic Delay Diversity

2.1 CDD-OFDM System Structure

CDD is a low complexity spatial diversity scheme, where multiple transmit antennas transmit delayed versions of the same signal. Since the cyclic delays are inserted, inter-symbol interference (ISI) can be avoided, and orthogonality among sub-carriers is maintained. Essentially, a multiple-input single-output (MISO) channel is transformed into an equivalent SISO channel with increased frequency selectivity, i.e., the spatial diversity is transformed into frequency diversity [3].

The block diagram shown in Fig. 1 shows the transmitter structure of the OFDM system, which employs N transmit antennas and uses CDD. First, the information bits are encoded by an FEC encoder. Since channel coding can not correct burst errors, the FEC encoder is followed by an interleaver to map adjacent bits to uncorrelated sub-carriers, and then reduce errors. After symbol mapping, for example, on PSK symbols, OFDM is implemented via the

inverse fast Fourier transform (IFFT) of size N_{FFT} , where N_{FFT} is the number of sub-carriers. After IFFT, the signal is fed into the N transmit antennas. The cyclic shift value on the first antenna is set to zero, while in other branches the signals are cyclically shifted by specific cyclic shift values $\delta_{cyc,n}$ samples, where $n=1, \dots, N-1$. The cyclic shift of the symbols in the time-domain transforms the symbol into phase diversity (PD) in the frequency-domain. Delayed signals are appended by the CP before being transmitted.

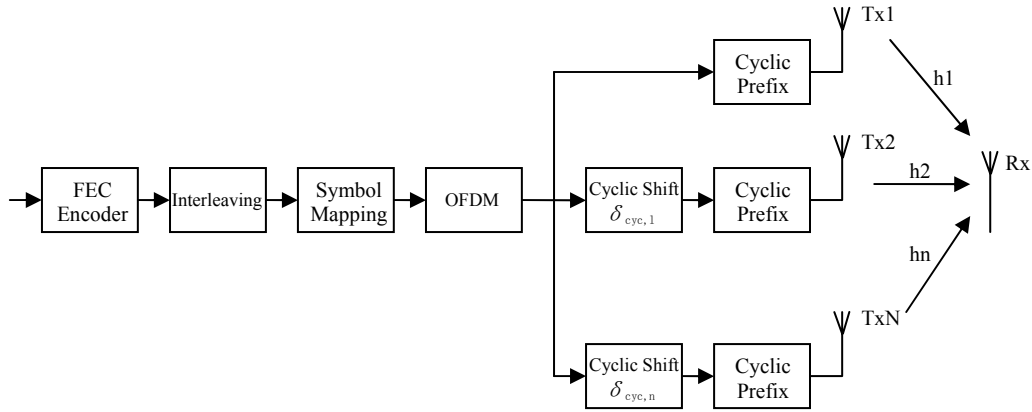

Fig. 1. CDD-OFDM transmission scheme

The equivalence of PD and CDD is a property of the fast Fourier transformation (FFT), and can directly be seen from the length N_{FFT} IFFT definition. The transmitted signal is given by

$$s(l) = \frac{1}{\sqrt{N_{FFT}}} \sum_{k=0}^{N_{FFT}-1} S(k) e^{j \frac{2\pi}{N_{FFT}} kl}, \quad (1)$$

and

$$s((l - \delta_{cyc,n}) \bmod N_{FFT}) = \frac{1}{\sqrt{N_{FFT}}} \sum_{k=0}^{N_{FFT}-1} e^{-j \frac{2\pi}{N_{FFT}} k \delta_{cyc,n}} S(k) e^{j \frac{2\pi}{N_{FFT}} kl}, \quad (2)$$

where $s(l)$ and $S(k)$ denote the complex-valued signals in time and frequency domain, respectively. Also, k and l denote the frequency and the time indexes, respectively.

At the receiver side, the receiver processes the sum signal by simply removing the CP, and performing the inverse-OFDM (IOFDM) modulation. This conventional receiver structure is possible, since the cyclic shifting makes the received sum signal appear as a multipath signal at the receiver. Thus, no special combining or other additional operations is necessary. The phase rotation caused by cyclic delay can be compensated by the equalizer at the receiver side. The channel decoder can exploit the diversity of the frequency selective fading channel due to the use of the interleaver.

2.2 Cyclic Delay Diversity Analysis

In the CDD-OFDM system, a MISO channel can be transformed into an equivalent SISO channel by cyclic shifting, and the frequency selectivity of the channel is increased. Thus, when channel coding and interleaving are used, we can achieve a better system performance.

Actually, cyclic shifts can not in fact reduce the total number of error bits, but it can change the error distribution, and thus improve the channel decoder performance. After the cyclic delay, the error bits of the transmit signal have a more dispersive distribution than the normal case without cyclic delay. In [4], two figures are presented to explain this kind of error distribution change. Fig. 2 and 3 show the uncoded error distribution in the time-frequency-plane for transmission over a flat fading channel with CDD and without CDD, respectively. The FFT size is $N_{FFT}=64$ and the cyclic delay on antenna 2 is $\delta_{cyc,I}=2$ samples. This change in the error distribution means that a larger number of OFDM symbols contain errors, and it reduces the probability of consecutive burst errors. After de-interleaving and channel decoding at the receiver, the system performance is improved. From [5], it is clear that better PER performance corresponds to enhanced system capacity.

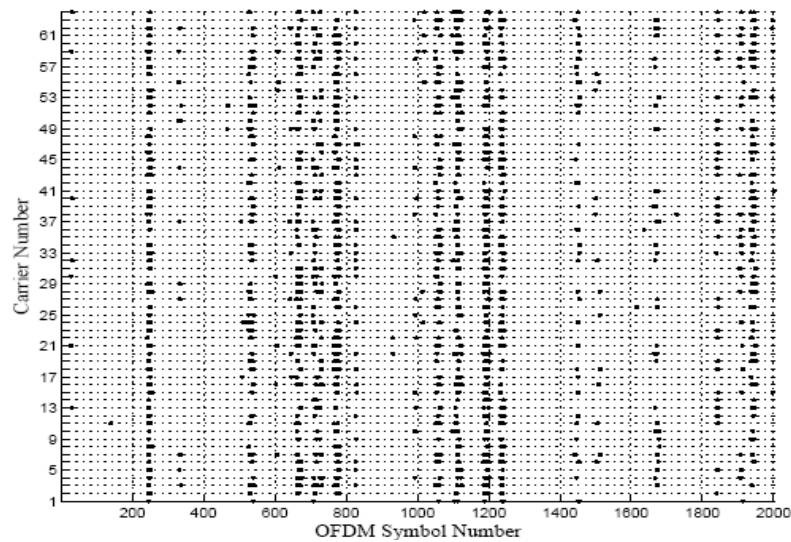

Fig. 2. Uncoded error distribution with CDD (• indicate error)

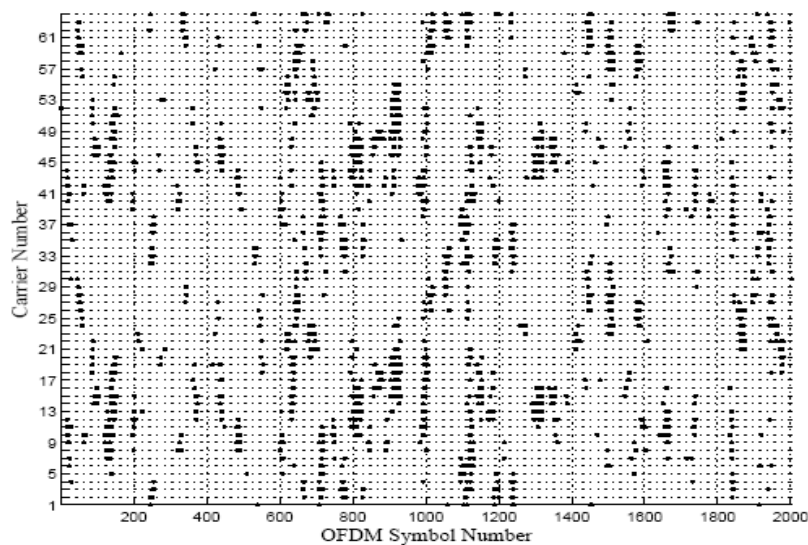

Fig. 3. Coded error distribution with CDD (• indicate error)

Fig. 4 shows the BER / PER performance over a flat fading channel with different cyclic delay values. Here, an OFDM system with two transmit antennas and one receive antenna is considered. The number of sub-carriers is $N_{FFT}=64$, and cyclic delay value on the second antenna is $\delta_{cyc,I}=16$ and $\delta_{cyc,I}=32$ samples, respectively. The mobility of the mobile station (MS) is 3 km/h. QPSK modulation and convolutional code with the coding rate of 1/2 are used. The constraint length is 7. From **Fig. 4**, it is clear that the system has a better BER performance when the cyclic delay value $\delta_{cyc,I}=16$ samples is used, and shows a better PER performance also. The different cyclic delay values can introduce different frequency-selective degrees of the channel, and consequently, lead to different performances.

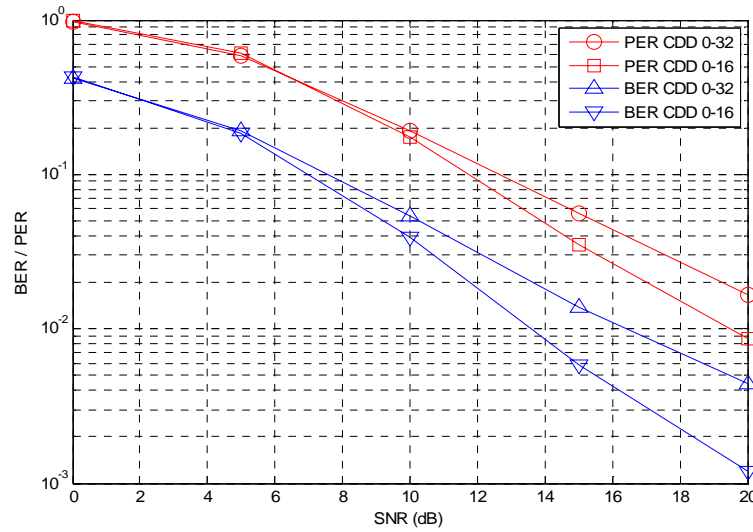

Fig. 4. BER / PER performance of the CDD-OFDM system with different cyclic delay values

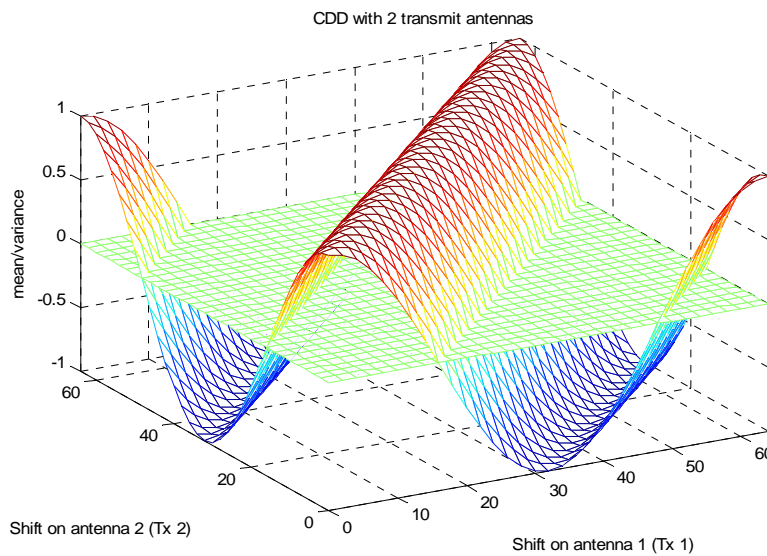

Fig. 5. Mean and variance of the transmitted signal with two transmit antennas.

Since different cyclic delays can cause different system performances, the means by which the optimal cyclic delay value can be obtained becomes of high importance. We can analyze this problem via Eq. (2), where the cyclic shift in the time-domain corresponds to a phase rotation in the frequency-domain.

The example shown in Fig. 5 depicts the mean and variance of the transmitted signal resulting from different cyclic shift values. The range of cyclic shifts on both antennas is $0 \leq \delta_{cyc,n} \leq N_{FFT}$, $n=1, 2$. The mean value remains constant while the variance is totally symmetric. The peak, which indicates the highest diversity, is achieved when the difference between the two shifts is maximal, i.e.

$$\Delta_{optimal} = |\delta_{cyc,1} - \delta_{cyc,2}| = 32. \quad (3)$$

Therefore, the system performance is dependent on the relative shift between antenna 1 and antenna 2. However, this analysis is based only on Eq. (2), which is the case excluding consideration of the effect of the time-varying channel. When the effects of interleaving and channel are considered, the position of the peaks in Fig. 5 may change, which means that the calculation of the optimal delay values should take into consideration all system parameters and the channel environment.

3. Closed-Loop MIMO Linear Precoding

In order to meet the ever increasing demand for higher data rates and better system performance, the coupling of OFDM and MIMO systems is regarded as a promising solution for next generation wireless networks. In MIMO systems, one effective way of obtaining the gains from the CSI is to use linear precoding. The precoder is a separate transmit processing block from channel. A linear precoder functions as a combination of an input shaper and a multi-mode beamformer with pre-beam power allocation [6].

Consider the singular value decomposition (SVD) of the precoder matrix

$$\mathbf{F} = \mathbf{U}_F \mathbf{D} \mathbf{V}_F. \quad (4)$$

The left-hand singular vectors \mathbf{U}_F are the orthogonal beam directions, where each column represents a beam direction. The beam power loadings are the squared singular values \mathbf{D}^2 . The right-hand singular vectors \mathbf{V}_F mixes the precoder input symbols to feed into each beam, and hence is referred to as the input shaping matrix. To conserve the total transmit power, the precoder must satisfy

$$tr(\mathbf{F}\mathbf{F}^*) = 1, \quad (5)$$

where $tr(\mathbf{X})$ denotes the sum of trace values of the matrix \mathbf{X} . Eq. (5) thus implies that the sum of power over all beams must be a constant.

Consider a system with an encoder producing a codeword \mathbf{c} , and a precoder \mathbf{F} at the transmitter. At the receiver, the received signal is

$$\mathbf{y} = \mathbf{H}\mathbf{F}\mathbf{c} + \mathbf{n}, \quad (6)$$

where \mathbf{H} is the MIMO channel matrix, and \mathbf{n} is the vector of additive white Gaussian noise (AWGN) with variance σ^2 . The receiver knows the precoding matrix \mathbf{F} and treats the combination $\mathbf{H}\mathbf{F}$ as an effective channel. Thus, it can detect and decode the received signal to obtain an estimate of the transmitted codeword \mathbf{c} .

4. Proposed Linear Precoding for CDD-OFDM Systems

The signal pre-processing techniques with multiple transmit antennas, e.g., CDD and STBC, etc., have been shown to result in a significant diversity gain. In order to exploit additional gain, we propose the introduction of a linear precoding technique to conventional CDD-OFDM systems. The proposed linear precoding scheme for FDD-OFDM systems with CDD is presented in Fig. 6. When the proposed scheme is used in TDD-OFDM systems with CDD, we do not utilize CSI feedback. Instead, the base station measures the up-link channel, and uses the measured CSI for the information transmission in the down-link channel.

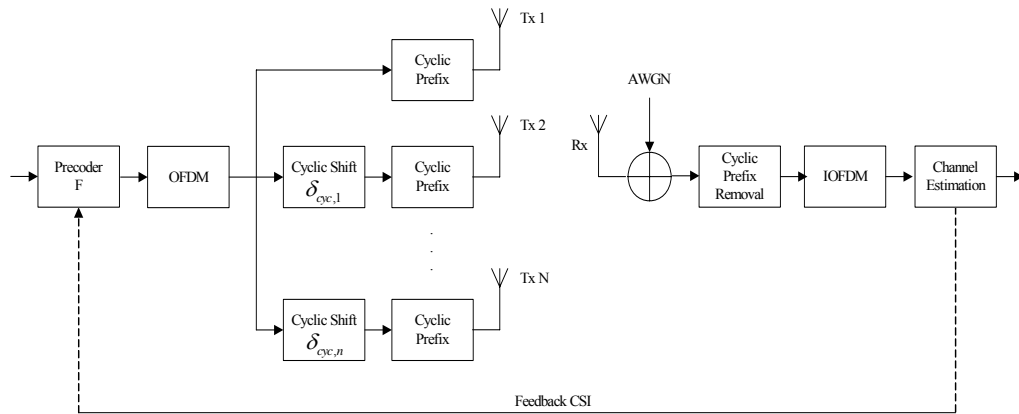

Fig. 6. Proposed precoding scheme for the CDD-OFDM system

In Fig. 6, since the cyclic shifting transforms the MISO channel into an equivalent SISO channel, we choose a SISO frequency-domain precoding scheme for CDD-OFDM systems. The transmitted signal after channel coding, interleaving and symbol mapping is precoded by a precoding matrix \mathbf{F} at the transmitter. The precoding matrix \mathbf{F} , which comes from the CSI feedback in FDD systems, is a function of the channel matrix \mathbf{H} . From Eq. (6), we note that the receiver treats the combination $\mathbf{H}\mathbf{F}$ as an effective channel matrix. Thus, an estimate of $\mathbf{H}\mathbf{F}$ is used in the channel equalization component before channel decoding at the receiver side.

The equivalent SISO channel in CDD-OFDM system is now represented by \mathbf{H}_{CDD} , when \mathbf{F}_{CDD} denotes the precoding matrix of the proposed scheme. So, the received signal is represented as

$$\mathbf{y} = \mathbf{H}_{\text{CDD}}\mathbf{F}_{\text{CDD}}\mathbf{c} + \mathbf{n}, \quad (7)$$

where \mathbf{c} is the transmitted codeword without cyclic-delay, and \mathbf{n} is the AWGN vector. The precoding matrix \mathbf{F}_{CDD} is obtained by inverting the estimated channel matrix \mathbf{H}_{CDD} . When the feedback latency is disregarded, and the channel is perfectly estimated, the fading effects of the channel can be greatly reduced and the performance matches that of the system in AWGN by precoding in Eq. (7). However, in fact the feedback information is susceptible to channel variation due to the delay in the feedback loop. The usefulness of the feedback depends on this delay and the channel Doppler spread. Thus, the simulation results for the proposed scheme with and without latency in various channel environments are presented in the next section.

5. Simulation Results

In this section, we provide simulation results for the proposed scheme, and a comparison with

conventional CDD-OFDM systems. The Ped A and Veh A channels employed are defined in [7]. **Table 1** shows the principal simulation parameters.

Fig. 7 shows the BER performance of the conventional CDD-OFDM system without precoding over flat fading, Ped A, and Veh A channels, respectively. The SNR is 19.4 dB for a BER of 10^{-4} over a flat fading channel with a mobility of 3 km/h. It is nearly the same as the performance in the Ped A channel over the whole SNR range. For a mobility of 120 km/h, the proposed system achieves the 10^{-4} BER performance at an SNR of 13.4 dB and 14.6 dB, over flat fading and the Veh A channels, respectively. The interesting phenomenon turned up here is that when the frequency selectivity and mobile speed increase, the system performance improves. This gain by CDD is similar to the gain by space-frequency block coding (SFBC) [8], since all of these two diversity schemes exploit the frequency diversity gain.

Table 1. System parameters

Parameter	Value
Carrier Frequency [GHz]	2
Systems Bandwidth [KHz]	800
FFT Size	64
Length of Guard Interval	16
Length of Cyclic Deal [samples]	0, 16
Frame Size [OFDM symbols]	50
Channel Coding	K=3, 1/2 Convolutional Code
Interleaving	Random Interleaving
Modulation	QPSK
Detection	Maximum Likelihood
MIMO Configuration	2×1
Fading Channels	Flat / Ped A / Veh A
Mobility [km/h]	3 & 120 for Flat 3 for Ped A 120 for Veh A
Feedback Latency [ms]	5 for FDD 0 for TDD

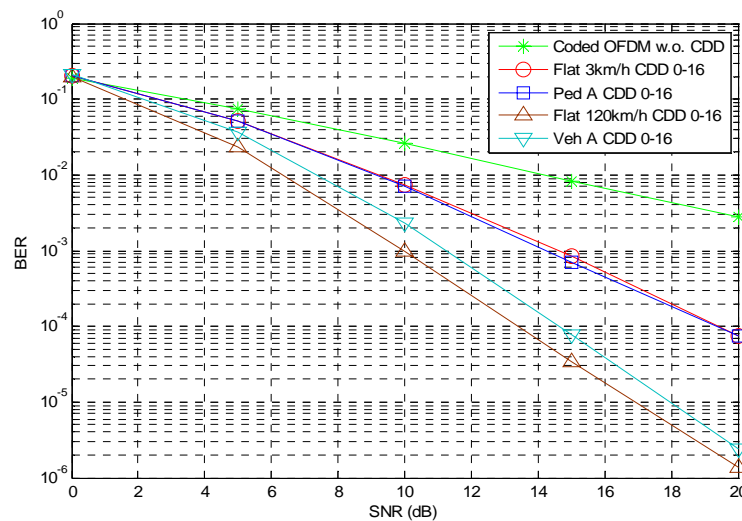

Fig. 7. BER performance of the CDD-OFDM system without precoding in various channel environments

For a fast time-varying channel in mobile communications, feedback techniques are usually effective up to a certain mobility, depending on the carrier frequency, the transmission frame length, and the feedback loop latency. The effects of feedback delay and error have been analyzed for various precoding techniques in 3GPP [9], revealing potentially severe performance degradation. Therefore, the optimal use of feedback depends on the quality of the feedback information. A frame length of 5 ms has been defined based on the IEEE 802.16 standard as one of the criteria for frame size. We assume the minimum feedback latency is 1 frame period in FDD systems, so 5 ms of frame length and feedback latency are adopted in simulations.

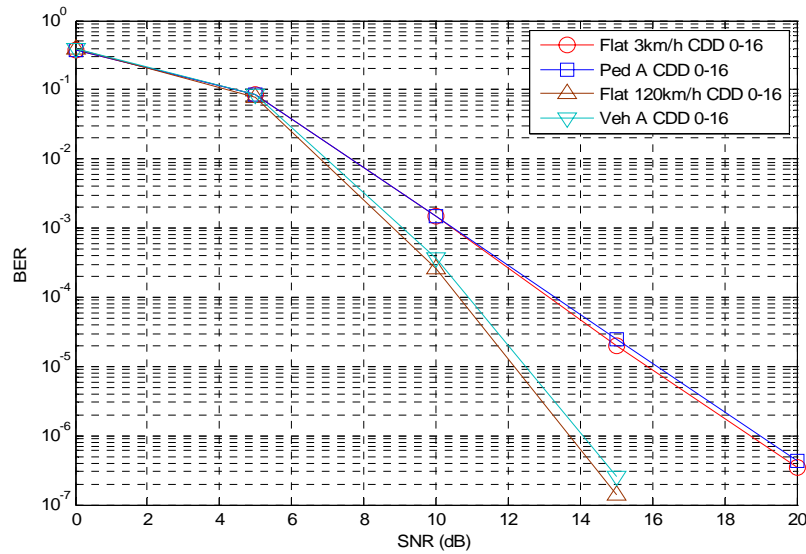

Fig. 8. BER performance of the CDD-OFDM system with precoding in various channel environments (no feedback latency)

Simulation results for the proposed CDD-OFDM system with linear precoding are presented in **Fig. 8**. The feedback loop latency is not considered in this simulation. By comparing **Fig. 7** with **Fig. 8**, we find that a significant improvement in BER performance is achieved via the proposed linear precoding technique. For a BER of 10^{-4} , a gain of 6.4 dB and 6.2 dB is obtained in a flat fading channel with a mobility of 3 km/h and the Ped A channel, respectively. On the other hand, a gain of 2.7 dB and 3.7 dB is attained in a flat fading channel with a mobility of 120 km/h and in the Veh A channel, respectively. Since the estimate of channel matrix $\hat{\mathbf{H}}_{\text{CDD}}$ includes the AWGN noise, and the precoding matrix \mathbf{F}_{CDD} is obtained by inverting the matrix $\hat{\mathbf{H}}_{\text{CDD}}$. So, this inaccurate precoding matrix can not eliminate the effect of channel completely, and eventually leads to the existence of the error bits.

Fig. 9 shows the performance when the CSI feedback latency is considered in FDD-OFDM systems with CDD. The frame length is set to 5 ms, which includes 50 OFDM symbols, and a minimum of 5 ms feedback latency is introduced in this simulation. In **Fig. 9**, the BER performance degrades seriously. We note that the performance only depends on the mobility, but it is largely independent of the delay spread. When compared with **Fig. 8**, for a BER of 10^{-3} , the performance is degraded by 9 dB in a flat fading channel with a mobility of 3 km/h, and it is degraded by 10 dB in the Ped A channel. There is a 5.5 dB degradation in a flat fading channel with a mobility of 120 km/h, while the performance in Veh A channel is degraded by almost 5.4 dB for a BER of 10^{-3} . The performance shown in **Fig. 9** is even much worse than the

performance achieved in the simulations of the conventional CDD-OFDM systems without precoding.

The results shown in **Fig. 9** indicate that the accuracy of the CSI has a significant effect on the performance of the proposed scheme. Thus, the proposed scheme is more suitable for the TDD-OFDM systems with CDD, where the channel reciprocity holds. This reciprocity principle suggests that the transmitter can obtain information about the forward channel from the reverse channel measurements. In practical full-duplex communication, the forward and reverse links are not under all the identical frequency, time, and spatial instances. However, the reciprocity principle may still hold approximately if the difference in any of these dimensions is relatively small, compared to the channel variation across the referenced dimension.

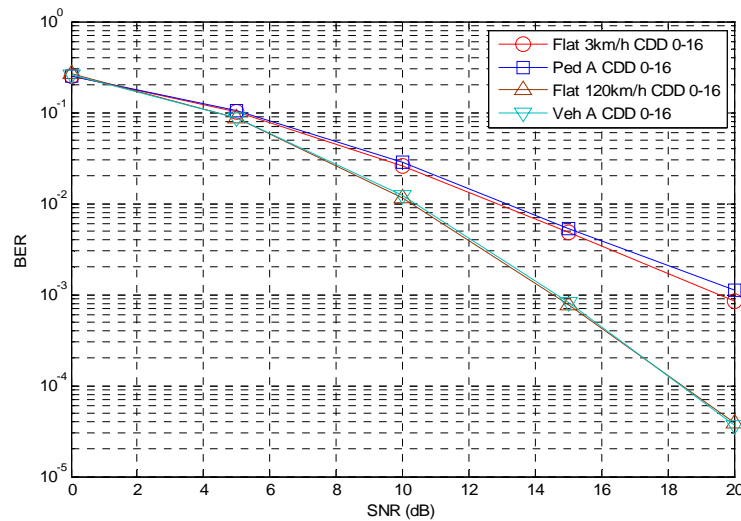

Fig. 9. BER performance of the CDD-OFDM system with precoding in various channel environments (FDD with feedback latency)

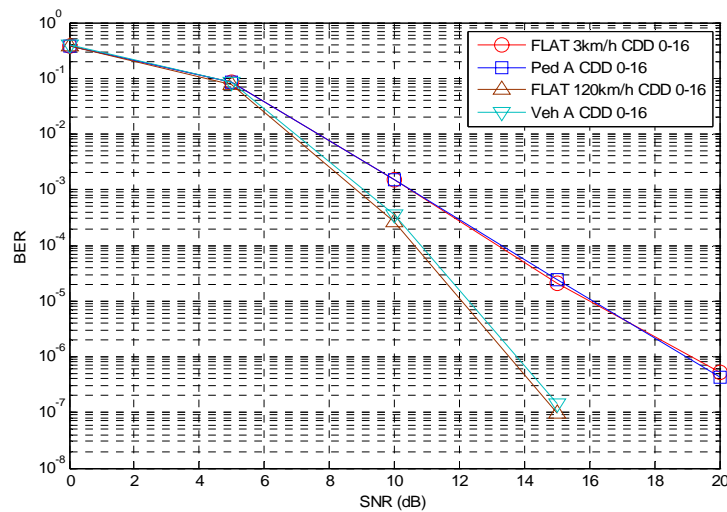

Fig. 10. BER performance of the CDD-OFDM system with precoding in various channel environments (TDD, latency-free)

Fig. 10 shows the link level simulation results for TDD-OFDM systems with CDD. No latency is considered since the time gap between the down-link and the up-link in TDD is 2 - 3 OFDM symbols, which is relatively small compared with a 5 ms latency, thus it can be disregarded. For the purpose of comparison, the total transmit power in the up-link is set to be identical to that in the down-link, to guarantee the accuracy and the reliability of channel estimation. As shown in **Fig. 10**, the proposed system achieves a BER of 10^{-4} at an SNR of 13.1 dB and 13.2 dB for a flat fading channel with a mobility of 3 km/h and the Ped A channel, respectively. These performances are almost identical over the whole SNR range. The proposed system achieves a BER of 10^{-4} at an SNR of 10.6 dB and 10.8 dB for a flat fading channel with a mobility of 120 km/h and the Veh A channel, respectively. Comparing **Fig. 10** with **Fig. 8**, the system performance is almost same for all cases. This is because that the reciprocity principle is still approximately satisfied in TDD case, since the difference between the down-link channel and the up-link channel is relatively small. This result indicates that the proposed scheme is suitable for TDD-OFDM systems with CDD, where a highly quality CSI can be guaranteed via the reciprocity principle.

6. Conclusions

CDD is a simple approach used to exploit the frequency diversity without increasing the complexity of conventional communication systems. Also, precoding techniques have been frequently adopted to improve the system performance. In this paper, we proposed applying the linear precoding technique to the conventional CDD-OFDM systems, where additional precoding gain is achieved. When feedback latency is disregarded, it is found that the proposed combination of the linear precoding technique with CDD can achieve a high gain compared with conventional CDD-OFDM schemes in various channel environments. However, a length of 5 ms feedback latency seriously degrades the BER performance in FDD-OFDM systems with CDD. In TDD-OFDM systems with CDD, when the reciprocity holds, the performance achieved by the proposed scheme is almost identical to that in the latency-free case. The channel reciprocity and transformation between the down-link and up-link channels in FDD / TDD systems are issues for future research.

References

- [1] A. Dammann and S. Kaiser, "Low complex standard conformable antenna diversity techniques for OFDM systems and its application to The DVB-T system," In *Proc. 4th International ITG Conference on Source and Coding*, pp. 253-259, Jan. 2002.
- [2] S. Alamouti, "A simple transmit diversity technique for wireless communications," *IEEE J-SAC*, vol. 16, pp. 1451-1458, Oct. 1998.
- [3] Ting Du, Bing Hui, and KyungHi Chang, "Block coding techniques with cyclic delay diversity for OFDM systems," *KICS Journal*, vol. 33, no. 9, pp. 867-873, Sep. 2008.
- [4] M. Bossert, A. Huebner, F. Schuehle, H. Haas, and E. Costa, "On cyclic delay diversity in OFDM based transmission schemes," In *Proc. OFDM Workshop*, Sep. 2002.
- [5] G. Andrews, A. Ghosh, and R. Muhamed, *Fundamentals of WIMAX-Understanding Broadband Wireless Networks*. Prentice Hall. USA: NJ, 2007.
- [6] Mai Vu and Arogyaswami Paulraj, "MIMO wireless linear precoding," *IEEE Signal Processing Magazine*, vol. 24, pp. 86-105, Sep. 2007.
- [7] *Recommendation ITU-R M.1225*, Guidelines for evaluation of radio transmission technologies for IMT-2000. 1997.

- [8] Insoo Sohn, Heesoo Lee, and Jae Young Ahn, "Comparison of SFBC and STBC for transmit diversity in OFDM system," IEEE C802.20-03/49, May 2003.
- [9] A. Hottinen, O. Tirkkonen, and R. Wichman, Multi-antenna Transceiver Techniques for 3G and Beyond. Wiley & Sons, Inc., 2003.

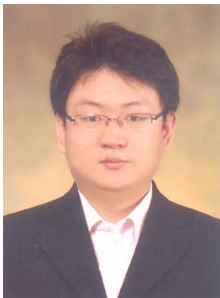

Bing Hui received a BS degree in communication engineering from Northeastern University, Shenyang, China, in 2005. He is currently studying for a MS degree at the Graduate School of Information Technology and Telecommunications, Inha University, Incheon, Korea. He has been involved in the R&D projects, whose topics are MIMO-OFDM algorithm including detection, and dirty paper coding type of precoding techniques. His research interests include 4G wireless communication systems, WiMAX, and the 3GPP LTE systems.



KyungHi Chang received BS and MS degrees in electronics engineering from Yonsei University, Seoul, Korea, in 1985 and 1987, respectively. He received his PhD degree in electrical engineering from Texas A&M University, College Station, Texas, in 1992. From 1989 to 1990, he was with the Samsung Advanced Institute of Technology (SAIT) as a member of research staff and was involved in digital signal processing system design. From 1992 to 2003, he was with Electronics and Telecommunications Research Institute (ETRI) as a principal member of technical staff. During this period, he led the design teams working on WCDMA UE modem and 4G radio transmission technology. He is currently with the Graduate School of Information Technology and Telecommunications, Inha University, where he has been a professor since 2003. His current research interests include RTT design for IMT-Advanced and 3GPP LTE systems, WMAN system design, cognitive radio, cross-layer design, cooperative relaying systems, and RFID/USN. Dr. Chang has served as a senior member of IEEE since 1998. Currently, he is an editor-in-chief of the Korean Institute of Communication Sciences (KICS) Proceedings. He has also served as an editor of ITU-R TG8/1 IMT.MOD, and he is currently an international IT standardization expert of the Telecommunications Technology Association (TTA).